

NOTES:

- ALL DIMENSIONS ARE IN MILLIMETERS(mm) UNLESS NOTED OTHERWISE
- AS FAR AS PRACTICABLE, JUNCTIONS AND SERVICE CONNECTIONS SHALL BE BUILT IN FOR ALL PLANNED USERS WHEN THE SEWER IS BEING CONSTRUCTED. WHERE IT IS NECESSARY TO MAKE A POST-CONSTRUCTION CONNECTION THE DEVELOPER SHALL BRING THE SEWER TO THE INSPECTION CHAMBER, INSTALL THE INSPECTION CHAMBER AND SEAL THE UPSTREAM END UNTIL THE CONNECTION IS REQUIRED.
- THE VERTICAL ANGLE BETWEEN THE SERVICE CONNECTING PIPE & THE HORIZONTAL SHALL BE GREATER THAN 0° AND NOT MORE THAN 60°
- WHERE THE CONNECTION IS BEING MADE TO A SEWER WITH A NOMINAL INTERNAL DIAMETER OF 300mm DIAMETER OR LESS, CONNECTION SHALL BE MADE USING 45° ANGLE JUNCTIONS
- WHERE THE CONNECTION IS BEING MADE TO A SEWER WITH A NOMINAL INTERNAL DIAMETER GREATER THAN 300mm
- IF THE DIAMETER OF THE CONNECTING PIPE IS GREATER THAN HALF THE DIAMETER OF THE SEWER, AN ACCESS MANHOLE SHALL BE CONSTRUCTED TO FORM THE CONNECTION POINT. OR
- IF THE DIAMETER OF THE CONNECTING PIPE IS LESS THAN OR EQUAL TO HALF THE DIAMETER OF THE SEWER, THEN THE CONNECTION SHALL BE MADE USING A PREFORMED SADDLE FITTING WITH A SLOW BEND BETWEEN THE SADDLE AND THE CONNECTING SEWER/DRAIN.
- CONNECTIONS MADE WITH SADDLE FITTINGS SHALL BE MADE BY CUTTING AND SAFELY REMOVING A CORE FROM THE PIPE AND JOINING THE SADDLE FITTING TO THE PIPE IN ACCORDANCE WITH THE MANUFACTURER'S INSTRUCTIONS TO ENSURE A WATER TIGHT JOINT. THE CONNECTING PIPE SHALL NOT PROTRUDE INTO THE SEWERS.
- TO IRISH WATER REVIEW, PROVIDED THE SADDLE OR BRANCH INCORPORATES A SWEEPED TEE CONNECTION TOWARDS THE DIRECTION OF FLOW

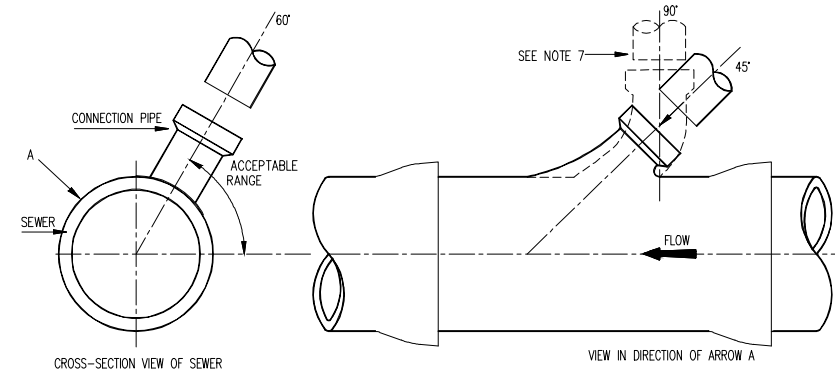
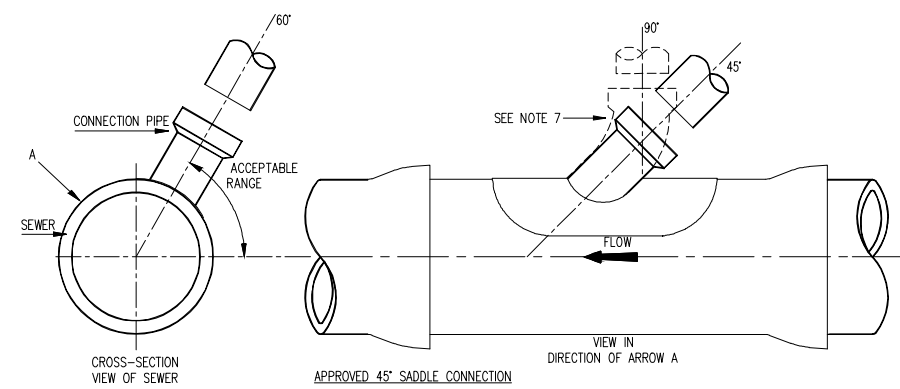

CRITICAL SEWER/SERVICE PIPE CONNECTION STD-WW-04

SCALE 1:25

NOTES:

- ALL DIMENSIONS ARE IN MILLIMETERS(mm) UNLESS NOTED OTHERWISE
- CONCRETE PIPE BEDS AND HAUNCHES MAY BE REQUIRED TO ADDRESS MINIMUM COVER SITUATIONS, AND SHALL BE SUBJECT TO SUBMISSION AND ASSESSMENT BY IRISH WATER BEFORE ADVANCING WITH THE WORKS.
- CONCRETE PIPE BEDS AND HAUNCHES SHALL HAVE A MINIMUM THICKNESS OF 150mm WITH AN ABSOLUTE MINIMUM DEPTH OF COVER ABOVE THE EXTERNAL CROWN OF THE PIPE OF 750mm.
- CONCRETE TO BE IN ACCORDANCE WITH IS EN 206 AND TO BE CLASS C16/20.
- THE HAUNCHES AND SURROUNDS TO BE FORMED USING FORM WORK TO PROVIDE A ROUGH CAST FINISH.
- EXPANSION JOINTS IN THE CONCRETE SHALL BE PROVIDED AT ALL PIPE JOINTS TO ALLOW FOR PIPE FLEXIBILITY, COMPRESSIBLE FILLER BOARD TO BE IN ACCORDANCE WITH BS EN 622-1 AND BS EN 622-4, AND TO BE 18mm THICK.
- POLYETHYLENE PIPES SHALL BE WRAPPED IN PLASTIC SHEETING HAVING A COMPOSITION IN ACCORDANCE WITH BS 6076 BEFORE BEING CAST INTO CONCRETE.
- BITUMINOUS MATERIAL SHALL NOT BE PUT IN CONTACT WITH PE OR PVC PIPES

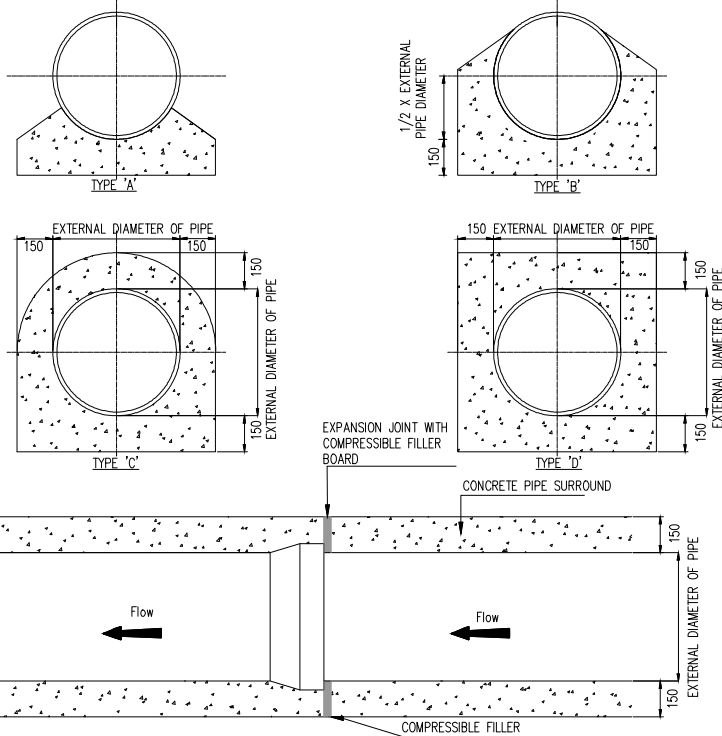

CONCRETE BED, HAUNCH AND SURROUND TO WASTEWATER PIPES STD-WW-08

SCALE 1:25

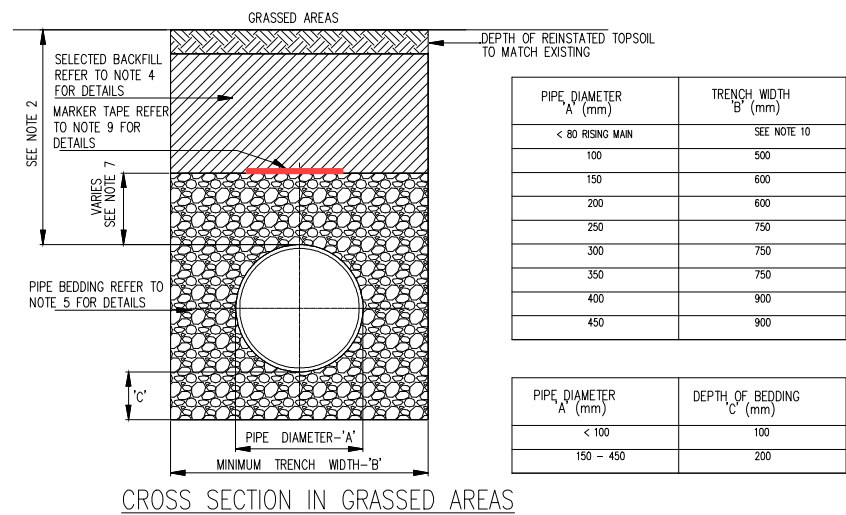

CROSS SECTION IN GRASSED AREAS

TRENCH BACKFILL AND BEDDING STD-WW-07

SCALE 1:25

NOTES:

- ALL DIMENSIONS ARE IN MILLIMETERS (mm) UNLESS NOTED OTHERWISE.
- PRE-CAST MANHOLES UNITS: COMPLYING WITH REQUIREMENTS OF IS EN 1917 AND BS 5911-PART 3.
- THICKER MANHOLE BASES REQUIRED FOR SEWERS IN EXCESS OF 3m DEEP WHERE THE SIZE IS GREATER THAN THE STANDARD MINIMUM SIZE.
- APPROVED PRE-CAST CONCRETE BASES MAY BE USED INCORPORATING CHANNELS, BENCHING ETC. SUBJECT TO IRISH WATER REVIEW AND COMPLYING WITH BS 5911-PART 4 2002.
- STRUCTURAL DESIGN AND REINFORCEMENT DETAILS TO BE PROVIDED BY THE DEVELOPER AND SUBMITTED TO IRISH WATER FOR REVIEW.
- MANHOLES GREATER THAN 3m IN DEPTH WILL REQUIRE A DETAILED STRUCTURAL DESIGN AND BE SUBJECT TO IRISH WATER REVIEW.
- MANHOLE ROOFS SHALL CONSIST OF RE-INFORCED CONCRETE SLAB OF IN-SITU CONCRETE, C30/37, WITH A MINIMUM THICKNESS OF 225mm DESIGNED TO CARRY ALL LIVE AND DEAD LOADS. ALTERNATIVELY, APPROVED PRE-CAST CONCRETE ROOF SLABS MAY BE USED SUBJECT TO IRISH WATER REVIEW AND COMPLIANCE WITH BS 5911 PART 4: 2002.
- COVERS AND FRAMES SHALL BE SUITABLE FOR ROAD AND TRAFFIC CONDITIONS SUBJECT TO APPROVAL FROM IRISH WATER.
- 200mm ALL AROUND, 100mm DEEP CONCRETE PLINTH WITH PROTECTIVE STAINLESS STEEL METAL BAND AROUND COVERS IN GREEN AREAS.
- ALL CHAMBERS TO BE CHECKED FOR UPLIFT BY THE DEVELOPER BASED ON GROUND CONDITIONS WITHIN THE SITE. SHOULD ANTI FLOATION MEASURES BE REQUIRED THEY SHALL BE SUBJECT TO REVIEW BY IRISH WATER.
- ALL CONCRETE TO BE IN ACCORDANCE WITH IS EN 206 : 2013.
- ANY SPECIAL ROAD REINSTATEMENT AROUND COVER & FRAME SHALL BE TO ROAD AUTHORITY'S REQUIREMENTS.
- NEW ROAD CONSTRUCTION & SURFACE FINISH TO BE TO ROAD AUTHORITY REQUIREMENTS.
- EXISTING ROAD REINSTATEMENT TO COMPLY WITH CURRENT VERSION OF "GUIDELINES FOR MANAGING OPENINGS IN PUBLIC ROADS" BY THE DEPT. OF TRANSPORT, TOURISM & SPORT, OR TRANSPORT INFRASTRUCTURE IRELAND REQUIREMENTS.
- IF DEPTH FROM GROUND TO PIPE SOFFIT IS GREATER THAN 6m DEEP, A SITE SPECIFIC ENGINEERED SOLUTION FOR ACCESS SHALL BE PROVIDED.
- PROPRIETARY WATER TIGHT PCC MANHOLE RING SYSTEMS WITH A WALL THICKNESS > 125mm, & A WATER TIGHT JOINT SEALING SYSTEM, MAY BE USED WITHOUT CONCRETE SURROUND, SUBJECT TO THE GROUND WATER LEVEL AT THE MANHOLE BEING LOW, & SUBJECT TO REVIEW BY IRISH WATER.

MANHOLE COVER AND FRAME SHALL COMPLY TO IS EN 124 AND BS 7903 (ALL CLASS D400 COVERS SHALL HAVE MIN. FRAME DEPTH 100-150mm) MIN OPE. 600x600mm

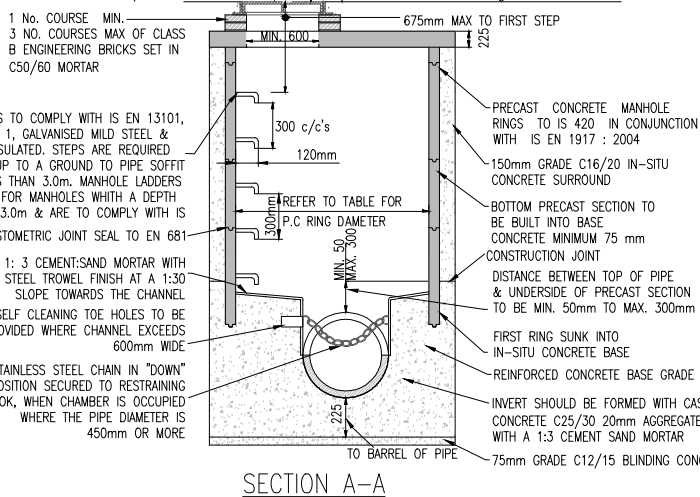

SECTION A-A

PRE-CAST CONCRETE MANHOLE STD-WW-10

SCALE 1:25

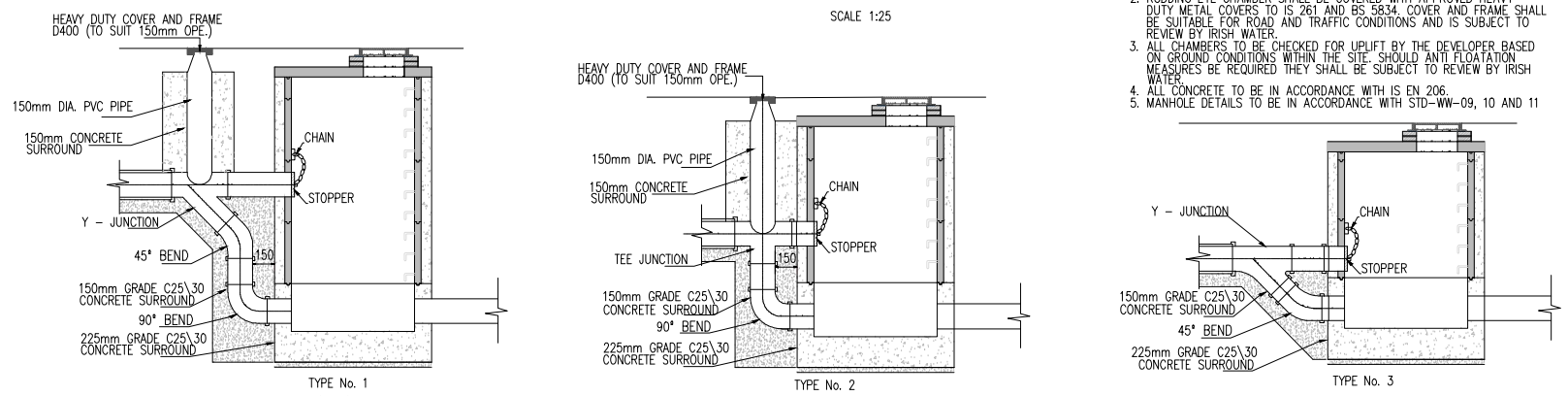

BACKDROP MANHOLES STD-WW-12

SCALE 1:25

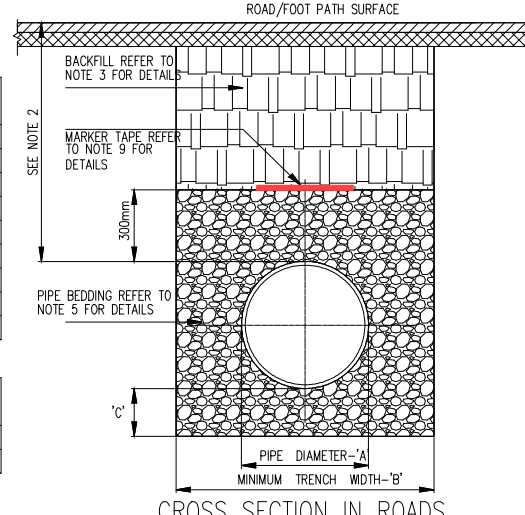

CROSS SECTION IN ROADS

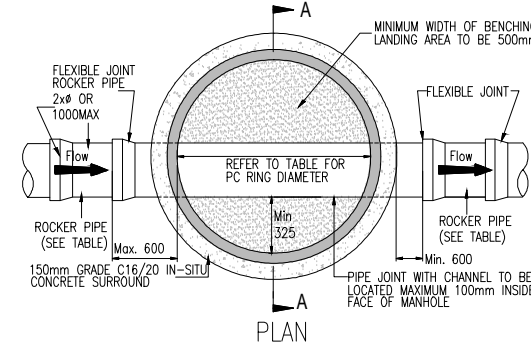
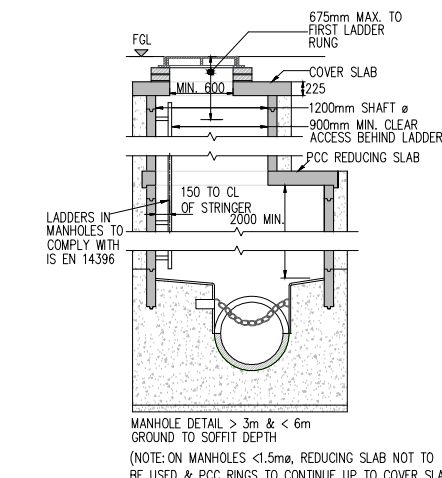

PLAN

MINIMUM MANHOLE DIAMETERS		ROCKER PIPE LENGTH	
DIAMETER OF LARGEST PIPE IN MANHOLE (mm)	INTERNAL DIAMETER OF MANHOLE (mm)	DIAMETER OF LARGEST PIPE IN MANHOLE (mm)	INTERNAL DIAMETER OF MANHOLE (mm)
LESS THAN 375	1200	150 TO 600	600
375 TO 450	1350	GREATER THAN 600 TO 750	1000
500 TO 750	1500	GREATER THAN 750	1250

NOTES:

- ALL DIMENSIONS ARE IN MILLIMETERS (mm) UNLESS NOTED OTHERWISE.
- THE MINIMUM DEPTH OF COVER FROM THE FINISHED SURFACE TO THE CROWN OF GRAVITY PIPES WITHOUT PROTECTION SHOULD BE AS FOLLOWS:
 - GARDENS AND PATHWAYS WITHOUT ANY POSSIBILITY OF VEHICULAR ACCESS - DEPTH NOT LESS THAN 0.5 M. (THIS WOULD NORMALLY RELATE TO DRAINS IN PRIVATE PROPERTY, SHALLOW PIPES OF THIS NATURE ARE UNDESIRABLE AND SHOULD BE INSTALLED IN ACCORDANCE WITH THE CURRENT BUILDING REGULATIONS).
 - DRIVEWAYS, PARKING AREAS AND YARDS WITH HEIGHT RESTRICTIONS TO PREVENT ENTRY BY VEHICLES WITH A GROSS VEHICLE WEIGHT IN EXCESS OF 7.5 TONNES - DEPTH NOT LESS THAN 0.75 M.
 - DRIVEWAYS, PARKING AREAS AND NARROW STREETS WITHOUT FOOTWAYS (E.G. MEWS DEVELOPMENTS) WITH LIMITED ACCESS FOR VEHICLES WITH A GROSS VEHICLE WEIGHT IN EXCESS OF 7.5 TONNES - DEPTH NOT LESS THAN 0.9 M.
 - DEPTHS OF SEWERS IN GATED ESTATES SHALL BE SIMILAR TO THAT OUTLINED ABOVE.
 - AGRICULTURAL LAND AND PUBLIC OPEN SPACE - DEPTH NOT LESS THAN 0.9 M.
 - OTHER HIGHWAYS AND PARKING AREAS WITH UNRESTRICTED ACCESS TO VEHICLES WITH A GROSS VEHICLE WEIGHT IN EXCESS OF 7.5 TONNES - DEPTH NOT LESS THAN 1.2 M.
- CLAUSE 804/808 MATERIAL IN ACCORDANCE WITH THE NATIONAL ROADS AUTHORITY SPECIFICATION FOR ROAD WORKS IS TO BE USED AS BACKFILL MATERIAL WHERE THE SEWER MAIN IS LOCATED IN ROADS, FOOTPATHS OR WHEN THE NEAREST PART OF THE TRENCH IS WITHIN 1m OF THE PAVED EDGE OF THE ROADWAY. CLAUSE 804/808 IS TO BE COMPACTED AS PER CLAUSE 802 OF THE NATIONAL ROADS AUTHORITY SPECIFICATION FOR ROAD WORKS. CLAUSE 808 IS TO BE USED WITHIN 500mm OF CEMENT BOUND MATERIALS, CONCRETE PAVEMENTS, CONCRETE STRUCTURES OR CONCRETE PRODUCTS. OTHERWISE CLAUSE 804 MAY BE USED. ALTERNATIVE BACKFILL MATERIAL TO THAT DESCRIBED ABOVE (CLAUSE 804 OR CLAUSE 808) OF THE PIPE TRENCH WILL ONLY BE ALLOWED BY IRISH WATER WHERE THE ROADS AUTHORITY IN WHOSE FUNCTIONAL AREA THE DEVELOPMENT IS LOCATED, PROVIDES WRITTEN APPROVAL TO THE DEVELOPER TO THE USE SUCH ALTERNATIVE MATERIAL.
- SELECTED EXCAVATED MATERIAL MAY BE USED IN GREEN-FIELD AREAS ABOVE GRANULAR PIPE SURROUND MATERIAL SUBJECT TO THE APPROVAL OF IRISH WATER.
- PIPE BEDDING SHALL COMPLY WITH MIS 4-08-02 AND IGN 4-08-01 GRANULAR MATERIAL SHALL BE 14mm TO 5mm GRADED AGGREGATE OR 10mm SINGLE SIZED AGGREGATE IS EN 13242 CONCRETE BED HAUNCH & SURROUND WHERE REQUIRED SHALL BE TO STD-WW-08.
- IN SOFT GROUND CONDITIONS (CBR < 5) THE MATERIAL SHOULD BE EXCAVATED AND DISPOSED OF IN ACCORDANCE WITH THE WASTE MANAGEMENT ACT AND CLAUSE 808 MATERIAL IN ACCORDANCE WITH THE NATIONAL ROADS AUTHORITY SPECIFICATION FOR ROAD WORKS SHALL REPLACE THE EXCAVATED MATERIAL, WRAPPED IN GEO-TEXTILE WRAPPING. ALTERNATIVELY, SPECIAL PIPE SUPPORT ARRANGEMENTS, INCLUDING PILING ETC. MAY BE REQUIRED WHERE THE DEPTH OF SOFT MATERIAL IS EXCESSIVE. SUCH ARRANGEMENTS SHALL BE SUBJECT TO ASSESSMENT BY IRISH WATER BEFORE ADVANCING WITH THE WORK.
- IN GREEN FIELD AREAS, TYPE B BACKFILL (SELECTED EXCAVATED MATERIAL) WILL BE ALLOWED ABOVE THE SITE HAUNCH GRANULAR MATERIAL. IN THE CASE OF RIGID PIPES, A GRANULAR SURROUND OF A MINIMUM DEPTH OF 150mm ABOVE THE CROWN OF THE PIPE IS REQUIRED FOR FLEXIBLE PIPES, AND TYPE B MATERIAL MAY BE USED AS BACKFILL ABOVE THIS. ALL RISING MAINS IN GREENFIELD AREAS SHALL HAVE A MINIMUM COVER OF 300mm OF GRANULAR MATERIAL ABOVE THE EXTERNAL CROWN OF THE PIPE.
- PIPES SHALL NOT BE SUPPORTED ON STONES, ROCKS OR ANY HARD OBJECTS AT ANY POINT ALONG THE TRENCH. ROCK SHALL BE EXCAVATED TO A DEPTH OF 150mm BELOW THE ACTUAL DEPTH OF THE TRENCH WITH THE VOID FILLED WITH CLAUSE 808 MATERIAL IN ACCORDANCE WITH THE NATIONAL ROADS AUTHORITY SPECIFICATION FOR ROAD WORKS. THE GRANULAR MATERIAL SHALL BE LAID ABOVE THIS VOID BACKFILL MATERIAL.
- NON DEGRADABLE MARKER TAPE SHOULD BE INSTALLED 350mm FROM THE SURFACE OF THE ROAD. IN THE CASE OF NON METAL PIPE MATERIAL, THE MARKER TAPE SHOULD INCORPORATE A TRACE WIRE WHICH IS LINKED TO FITTINGS AND TERMINATED AT THE WASTE WATER PUMPING STATION AND THE DISCHARGE MANHOLE.
- TRENCH WIDTH FOR PIPE SIZE < 80mm MAY BE < 500mm SUBJECT TO CONSIDERATION BEING GIVEN TO THE TRENCH DEPTH, HEALTH & SAFETY, CONSTRUCTION ACCESS REQUIREMENTS.
- NEW ROAD CONSTRUCTION & SURFACE FINISH TO BE TO ROAD AUTHORITY REQUIREMENTS.
- EXISTING ROAD REINSTATEMENT TO COMPLY WITH CURRENT VERSION OF "GUIDELINES FOR MANAGING OPENING IN PUBLIC ROADS" BY THE DEPT. OF TRANSPORT, TOURISM & SPORT, OR TRANSPORT INFRASTRUCTURE IRELAND REQUIREMENTS.
- IT IS THE CONTRACTORS RESPONSIBILITY TO ENSURE THAT ALL WORKS ARE CONSTRUCTED IN ACCORDANCE WITH THE IRISH WATER CODE OF PRACTICE AND STANDARD DETAILS. THE CODE OF PRACTICE AND STANDARD DETAILS ARE AVAILABLE TO DOWNLOAD FROM THE IRISH WATER WEBSITE AT WWW.WATER.ie/CONNECTIONS/DEVELOPER-SERVICES/. WHERE THE DETAILS CONTAINED ON THIS DRAWING DIFFER FROM THE IRISH WATER CODE OF PRACTICE OR STANDARD DETAILS THIS MUST BE BROUGHT TO THE ATTENTION OF THE ENGINEER IMMEDIATELY. IRISH WATER STANDARDS WILL TAKE PRECEDENCE.

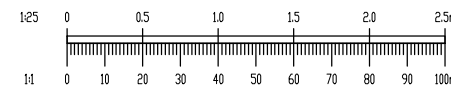

REV.	DATE	AMENDMENT	DRN	APPD

STATUS **FOR PLANNING ONLY NOT FOR CONSTRUCTION**

Waterman Moylan Engineering Consultants
 BLOCK 5, EASTPOINT BUSINESS PARK, ALFIE BYRNE ROAD, DUBLIN D03 K7W7 IRELAND.
 Tel: (01) 864 8900 Fax: (01) 861 3618
 Email: info@waterman-moylan.ie www.waterman-moylan.ie

CLIENT **KW PRS ICV ACTING FOR AND ON BEHALF OF ITS SUB-FUND KW PRS FUND 10**
 ARCHITECT **O'MAHONY PIKE ARCHITECTS**
 PROJECT **LANDS AT THE GRANGE, BREWERY ROAD, STILLORGAN, BLACKROCK, CO. DUBLIN**
 TITLE **PUBLIC FOUL WATER DRAINAGE DETAILS SHEET 1 OF 2**

DRAWN	DESIGNED	APPROVED	DATE
G.Byrne	EC	JG	AUG. '19
SCALE	JOB NO.	DRG. NO.	REVISION
AS SHOWN	01	18-093	P232